



ELECTRIC SCISSOR LIFT

AS0608E / AS0808E (AS2032E / AS2632E)

HIGHLIGHTS

LGMG E Series scissor lifts provides longer battery duty cycle life with its direct electric drive system. This range can be applied to various construction sites, maintenance job sites and other applications both indoor and outdoor. The wide range product line from 3.6m to 13.8m platform height can satisfy a range of different working height requirements.

- Battery powered, zero emission and quiet drive mean this machine is environmentally friendly.
- Efficient electric drive system provides longer-lasting performance and better gradeability.
- Proportional lift and drive controls deliver smoother operation.
- Swing out component trays for easy access and maintenance.
- Intelligent self-diagnostic system for quick troubleshooting.
- Commonality in parts with other scissor lifts.



LGMG Electric Motor Drive Scissor Lift

SPECIFICATIONS

MODELS	AS0608E (AS2032E)		AS0808E (AS2632E)	
Measurements	Metric	US	Metric	US
Working Height Max.	7.9m	25.9ft	10m	32.8ft
A Platform Height-Raised	5.9m	19.4ft	8m	26.2ft
B Platform Height-Stowed	1.03m	3.4ft	1.14m	3.7ft
C Platform Length	2.26m	7.4ft	2.26m	7.4ft
D Platform Width	0.79m	2.59ft	0.79m	2.59ft
E Overall Length(with ladder)	2.4m	7.9ft	2.4m	7.9ft
F Overall Width	0.83m	2.7ft	0.83m	2.7ft
G Overall Height-Rails Up	2.19m	7.2ft	2.32m	7.61ft
Overall Height-Rails Down	1.83m	6ft	1.95m	6.4ft
H Extension Deck	0.9m	3ft	0.9m	3ft
I Wheelbase	1.85m	73in	1.85m	73in
Ground Clearance(Stowed/Raised)	100/25mm	3.94/0.98in	100/25mm	3.94/0.98in
PRODUCTIVITY				
Platform Occupants Max. (in/out)	2/1	2/1	2/0	2/0
Platform Capacity	380 kg	838 lbs	230 kg	510 lbs
Platform Capacity-Extension	120 kg	265 lbs	120 kg	265 lbs
Drive Height	Full Height			
Gradeability-Stowed	25 %			
Turning Radius-Inside	0			
Turning Radius-Outside	2.15m	7ft	2.15m	7ft
Raise/Lower Speed	30/34 s	30/34 s	31/40 s	31/40 s
Brakes	Front-wheel Brake			
Drive Mode	4×2			
Tires Type	Solid Non-marking			
Tires Size	380×130mm	15×5in	380×130mm	15×5in
POWER				
Power Source	24V DC 225Ah			
HYDRAULIC SYSTEM				
Hydraulic Oil Capacity	13L	3.4gal	13L	3.4gal
WEIGHT				
Machine Weight(CE/ANSI)	2000kg	4409 lbs	2140kg	4718 lbs

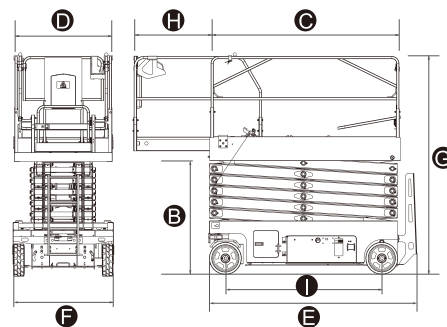

STANDARD FEATURES

- Proportional control
- Foldable guardrail
- Emergency stop device
- Manual brake release
- Emergency descent
- Swing-out component tray
- Pothole guard
- Self-lock entry gate
- Tilt alarm with lift cut-out
- Overload sensing system
- Descent alarm with flashing beacon
- Horn/hour meter
- All motions alarm
- Full-height drive
- Intelligent diagnostic system

OPTIONAL

- AC power to platform
- Platform anti-collision device
- Air tube to platform
- Maintenance-free battery
- Lithium battery
- GPS

Machines in compliant with EN280 / ANSI 92.20 Standard.

Specifications subject to change without notice. Photos and diagrams in the page are for promotional purposes only.
2020 V1 Version

LINGONG GROUP JINAN HEAVY MACHINERY CO., LTD.

Address: No. 2676, Kejia Road, Jinan, Shandong, China
Email: sales@lgmg.com.cn Tel: +86-0531-67879283

LGMG Europe B.V.

Address: Laanweg 16 3208LC Spijkenisse Rotterdam, The Netherlands

LGMG North America, Inc.

Address: 1445 Sheffler Dr, Chambersburg, PA. 17201, USA



RELIABILITY IN ACTION